

TYPICAL GULLY DETAILS

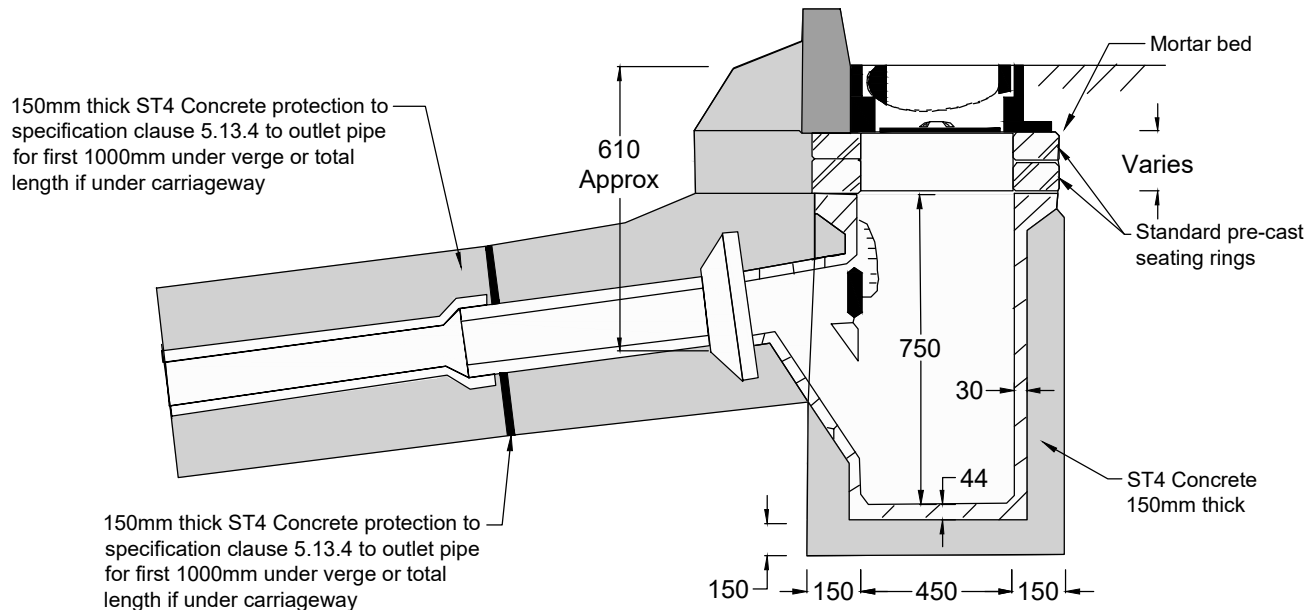

**TYPE G5
TRAPPED ROAD GULLY
N.T.S.**

NOTES

1. Cover and frame uncoated iron to Clause 5.11.1.
2. Mortar bed and benching to Clause 5.11.8.
3. Standard pre-cast seating rings to comply to BS 5911-4:2010
4. All in situ concrete to be ST4 with sulphate resisting cement unless agreed otherwise.
5. Position of outlet pipe varies in plan.
6. In situ ST4 concrete 150mm thick surround to outlet pipe for first one metre under verge or total length if under carriageway.
7. Where grating is to be trafficked or laid against within 24 hours of frame being placed in position, then a suitable Ultra rapid hardening mortar and concrete (Monoset 241 or similar) shall be used to bed cover and frame.

Rev: AMENDMENT DETAILS Date: Description: Approved by:



Checked by: -- Approved by: --

DRAFT

-/-

Typical Gully Details

This is a typical detail and may require conversion to a full scheme specific drawing.

NOT TO SCALE
(all units in millimetres)

Disclaimer : Before making use of this detail, any designer or third party must ensure that it satisfies all requirements of the scheme to which it is being applied. Lincolnshire County Council accept no responsibility for third party use of this Standard Detail.

SD/5/130
Standard Detail Number

Revision Number

Revision