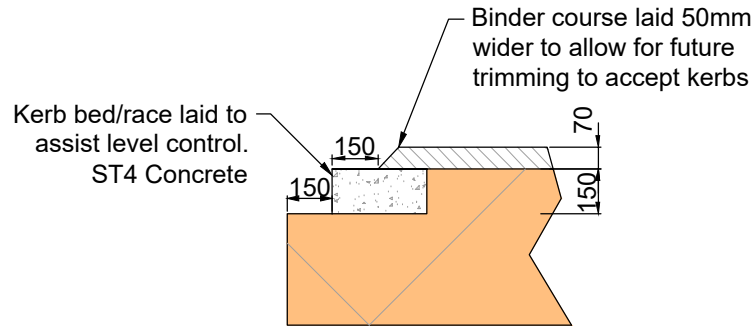
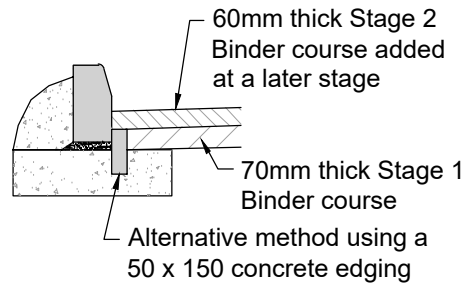
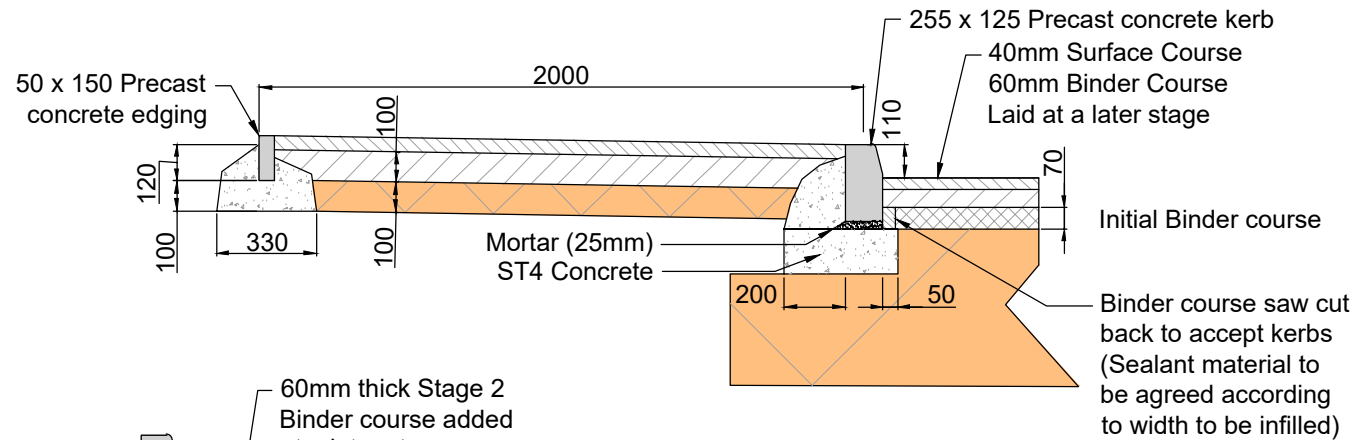

**Chart 1 Type Road Utilising Alternative Method of Kerb Installation
(Two stage construction; kerbing to be added at a later stage)**

STAGE 1



STAGE 2



Rev:	Date:	Description:	Approved by:
AMENDMENT DETAILS			

Lincolnshire
COUNTY COUNCIL

Checked by:	--	Approved by:	--
DRAFT		-/-/-	

Alternative Method of
Kerb Installation

This is a typical detail and may require conversion to a full scheme specific drawing.

NOT TO SCALE
(all units in millimetres)

Disclaimer : Before making use of this detail, any designer or third party must ensure that it satisfies all requirements of the scheme to which it is being applied. Lincolnshire County Council accept no responsibility for third party use of this Standard Detail.

SD/5/123
Standard Detail Number

Revision Number

Revision